

# Horizontal Current Profiling and Waves Measurement in one package



The Teledyne RDI 600-kHz Workhorse H-ADCP delivers up to 85m of horizontal profiling range

**T**eledyne RD Instruments' Workhorse Horizontal Acoustic Doppler Current Profiler (H-ADCP) is an acoustic monitoring system that "looks" out horizontally from its mounting structure to measure near-surface water currents and optional multi-directional waves. This revolutionary tool utilizes Teledyne RDI's patented Broadband signal processing to obtain an optimal combination of range, resolution, and data quality which cannot be obtained using narrowband products. The Workhorse H-ADCP measures currents at 128 individual points at up to 200 meters horizontal range, providing a detailed illustration of the complete flow structure centered at a single depth. The 300 kHz H-ADCP can be upgraded to add wave height and direction capabilities, fulfilling all your monitoring needs.



The Teledyne RD Instruments 300 kHz Workhorse H-ADCP delivers up to 200m of horizontal profiling range and optional multi-directional waves measurement

## Nine key operational advantages:

**Increased Range:** Our 300 kHz H-ADCP combines a lower frequency with a narrow  $<1^\circ$  beam to ensure an unparalleled profiling range of 200 meters or more for those applications requiring extended range. For smaller waterways our higher-frequency 600 kHz system delivers up to 85 meters horizontal range.

**Improved Data Reliability:** Teledyne RD Instruments' unique three-beam configuration provides a third beam for quality assurance, as well as data redundancy in the event of a blocked or damaged beam, ensuring the unmatched delivery of accurate data.

**Combined Current and Waves:** The narrow  $<1^\circ$  beam combined with extended range capability allows the 300 kHz H-ADCP to be upgraded to include our patented multi-directional waves-measurement option, providing you with a complete monitoring solution.

**Real-Time Data:** The H-ADCP provides unobtrusive real-time data for real-time decision-making.

**Increased Data:** The H-ADCP provides users with the capability to measure from 1 to 128 data points across a body of water, providing a highly detailed and accurate profile of the flow structure.

**Robust Construction:** The offshore environment is a demanding place, so we've designed the H-ADCP to rise to the challenge. The unit's sturdy design ensures a long life, and no calibration is ever required.

**Ease of Operation:** The H-ADCP is pre-configured for simple operation to ensure optimum performance with a minimal learning curve. System operation is further aided by an easy-to-use installation guide and intuitive Windows™ software.

**Remote Measurements:** The H-ADCP is ideal for mounting to large structures because measurements are made remotely, at ranges well beyond the influence of the structure on nearby current and wave fields.

**Ease of Mounting:** Horizontal orientation means no cables are exposed to damage on the seafloor.

## Workhorse H-ADCP Applications:

- Offshore Oil and Gas Platforms.** The 300 kHz H-ADCP collects critical surface current and multi-directional waves data for a real-time understanding of your offshore environment and the elements affecting your structure and production schedule.
- Renewable Energy.** The 300 kHz H-ADCP can be mounted on an offshore structure to provide real-time current and wave data for field site assessments and environmental monitoring.

- Vessel Traffic Safety.** The Workhorse H-ADCP provides port managers and pilots with the real-time environmental data need vessel traffic safety, efficiency and ship-docking applications.

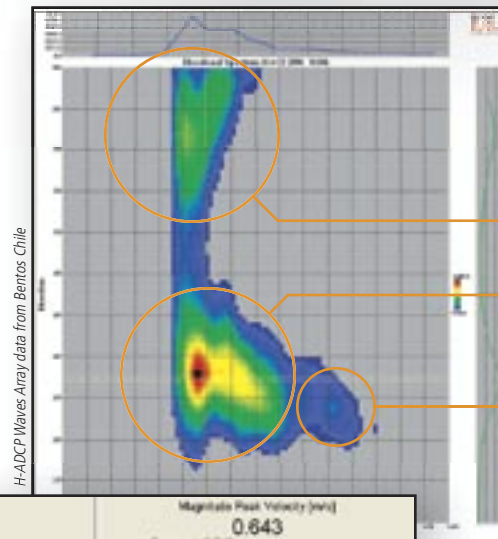

**H-ADCP Waves Data**  
Directional spectrum shows "multi-directional" swell  
Swell from Northwest  
Swell from West  
Sea from West

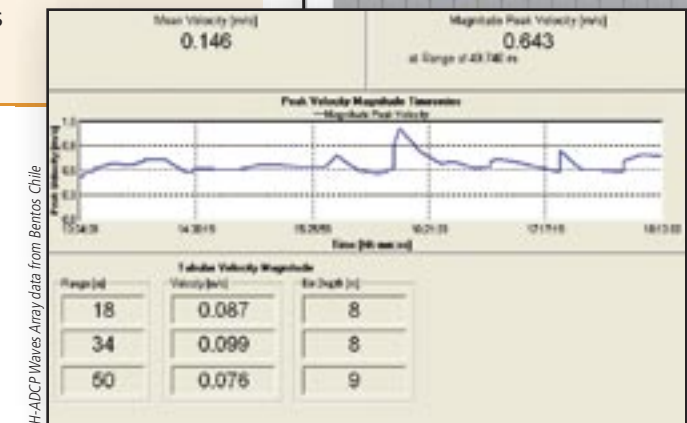

**H-ADCP Velocity Profile Data**  
Easy-to-interpret current profile data

**How it works...**  
In its simplest terms, the H-ADCP looks horizontally across a body of water measuring current and directional waves at numerous locations.

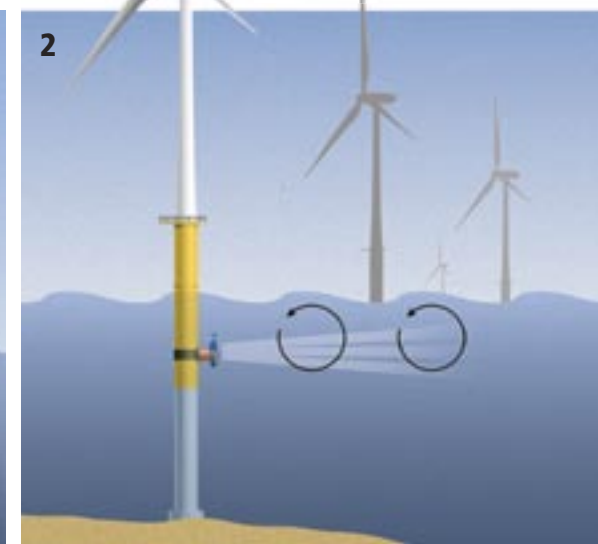
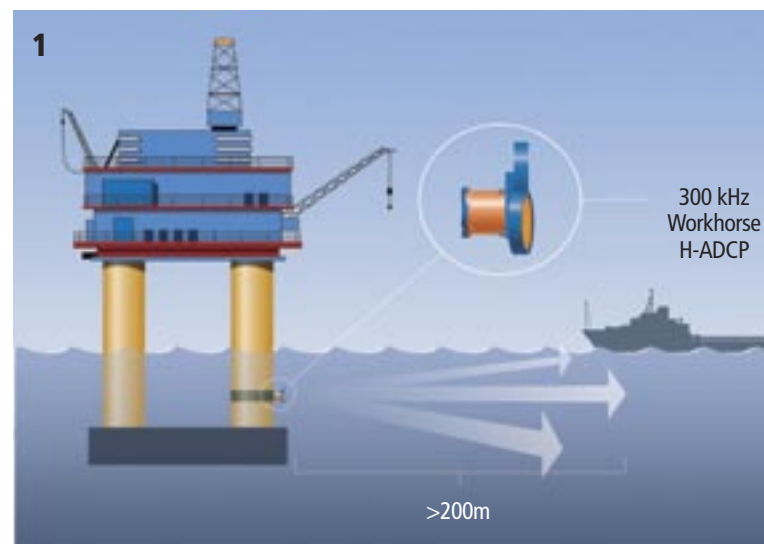
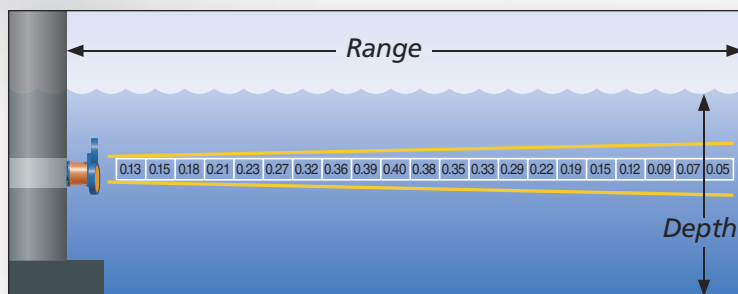

# Workhorse H-ADCP

TELEDYNE RD INSTRUMENTS MARINE MEASUREMENTS

## 300 kHz and 600 kHz LONG-RANGE HORIZONTAL ADCP



300 kHz



600 kHz<sup>1</sup>

### Technical Specifications

Range		
Typical max. range	250m	85m
Aspect ratio limitation	19/1 (range/total depth)	12/1 (range/total depth)
Profile Parameters		
Velocity accuracy	±0.5% of water velocity relative to H-ADCP ±0.5cm/sec	±0.25% of water velocity relative to H-ADCP ±0.25cm/sec
Velocity resolution	0.1cm/s	0.1cm/s
Velocity range	±5m/s (default);	±10m/s (maximum)
Number of depth cells	1–128	1–128
Error velocity data rejection	Yes; required on a single-ping basis to screen errors from passing vessels	
Transducer and Hardware		
Beam width	<1°	1.2°
Beam angle	20°	25°
Configuration	3-beam, convex	3-beam, convex
Communications	Serial port is switch-selectable for RS-232 or RS-422, ASCII or binary output at 1200–115,200 baud	

<sup>1</sup> This configuration also available in a lower-frequency model for use in deep sections where > 9/1 aspect ratio (range/total depth) is available.

### Environmental

Standard depth rating: 200m  
 Operating temperature: -5° to 45°C  
 Storage temperature: -30° to 75°C  
 Weight in air<sup>2</sup>: 300 kHz - 62.7 kg  
 600 kHz - 16.0 kg  
 Weight in water<sup>2</sup>: 300 kHz - 44.5 kg  
 600 kHz - 10.0 kg

<sup>2</sup> Without batteries

### Power

DC input: 20-50 VDC

### Options Available

- Memory: 2 PCMCIA slots, total 2GB
- Pressure sensor
- Directional waves array (available on the 300 kHz H-ADCP with <1° beam width only)

### Standard Sensors

**Temperature** (mounted on transducer):  
 Range: -5° to 45°C  
 Precision: ±0.4°C  
 Resolution: 0.01°

**Compass** (fluxgate type, includes built-in field calibration feature):  
 Accuracy: ±2°<sup>3</sup>  
 Precision: ±0.5°<sup>3</sup>  
 Resolution: 0.01°  
 Maximum tilt: ±15°

<sup>3</sup> @ 60° magnetic dip angle. 0.5G total field

### Communications

Serial port selectable by switch for RS-232 or RS-422. ASCII or binary output at 1200-115,400 baud.

### Dimensions

all in mm [inches]

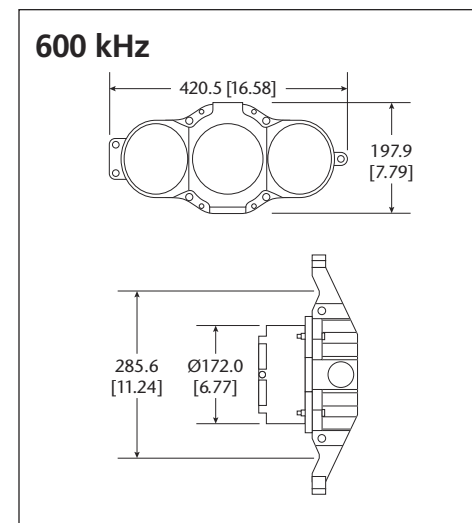
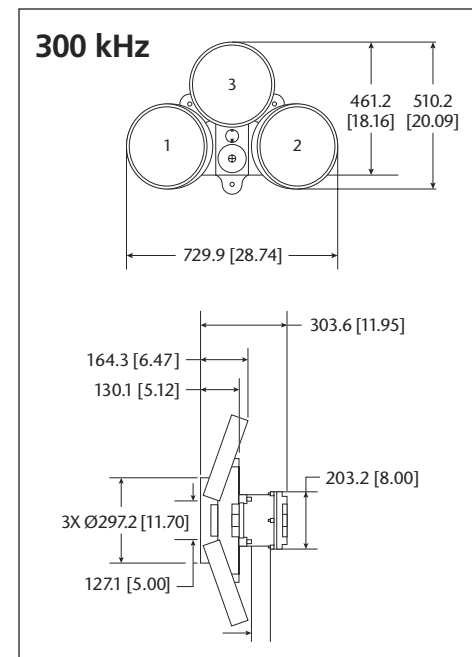

WORKHORSE  
 HORIZONTAL ACOUSTIC  
 DOPPLER CURRENT  
 PROFILER (H-ADCP)  
 PRODUCT LINE

**TELEDYNE RD INSTRUMENTS**  
 A Teledyne Technologies Company  
[www.rdinstruments.com](http://www.rdinstruments.com)

Free online product training

Free 24/7 emergency support

**Teledyne RD Instruments**  
 14020 Stowe Drive, Poway, CA 92064 USA  
 Tel. +1-858-842-2600 • Fax +1-858-842-2822 • E-mail: [rdisales@teledyne.com](mailto:rdisales@teledyne.com)  
 Les Nertieres 5 Avenue Hector Pintus 06610 La Gaude France  
 Tel. +33-49-211-0930 • Fax +33-49-211-0931 • E-mail: [rdie@teledyne.com](mailto:rdie@teledyne.com)

